



10 ton Electric Chain Hoist 1 Speed 380V 3ø 50HZ

Características Esenciales

- 3 Años de Garantía, Servicio y Atención al Cliente en Chile

Especificaciones Técnicas

Capacidad de Carga	10 ton	Longitud de cadena	160
Altura de Izaje Estandar (Customizable)	40 ft / 12 m	Humedad	20%~90%
Velocidad /min	10.63 ft @60Hz 2.70 mt @50Hz	Temperatura	-4 ~ 104° F / -20 ~ 40° C
Numero de Velocidades	1 Speed	Normas	ASME HST-1 , ASME B30.16 , EN60204-38
Voltaje	3 Phase 380V 50Hz	Garantía	3 Year
Potencia Total Watts	6000	Hoist Motor Power in KW	3+3
Clase de Servicio	H4/M5/2m/Class D	Hour Meter	Internal Working Hour Meter
Protección IEC Motor	IP55	Hoist Motor Insulation Grade	F
Control	Pendant Control IP66 and Optional Wireless	Hoist Contactor Coil Voltage	24 V
Voltaje del Control	24V	Hoist Contactors Amps	25A
Parada de Emergencia	Yes	Hoist Contactor Brand	Schneider
Tipo Transmisión / Reductor	Spur gearbox	IEC Hoist IP Protection	IP55
Tipo de Cadena	G100 Nikel	IEC Pendant Control Protection	IP66
Dimensiones de la Cadena	11.2 mm	Hoist Motor Brake Type and DC Voltage	DC170V
Caidas de Cadena	4		

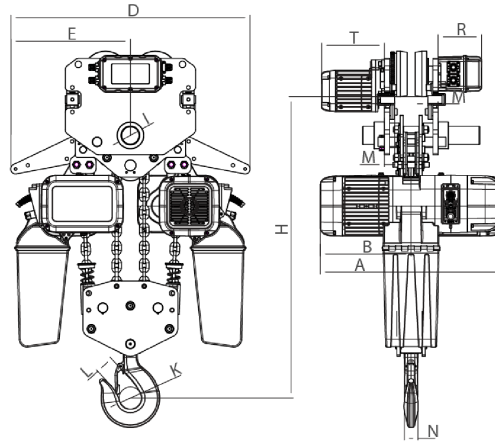

Rated load (t)	Type	Dimension (mm)												
		Minimum distance from the bottom of the track to the bottom hook: H	A	L	B	D	E	I	M	N	K	L	T	R
10	PWRXT10-04	1045	700	3500-5500	350	920	460	70	39	48	85	80	242	167

Peso & Dimensiones

H Altura Muerta	1005	Paquete 1 Peso Neto	638 lbs / 289 Kg
J Boca Gancho	85	Paquete 1 Ancho	30 in / 76.2 cm
A Altura Total	1200	Paquete 1 Peso Bruto	682 lbs / 309 Kg
Peso Total (sin cable o cadena)	345	Paquete 1 Altura	40 in / 101.6 cm
D Depth	700	Paquete 1 Profundidad	44 in / 111.76 cm
1st Package Type	Wood Crate		
W Ancho	920		
Peso Total	682 lbs / 310 Kg		

Detalles del Empaque

Referential Images / Imágenes Referenciales
Specifications may change without notice / las especificaciones pueden cambiar sin previo aviso