



10 ton Electric Chain Hoist 1 Speed 208~240V / 440~480V 3 ϕ 1/2 60HZ

Características Esenciales

- 3 Años de Garantía, Servicio y Atención al Cliente en Chile

Especificaciones Técnicas

Capacidad de Carga	10 ton	Power Cord Length and Phase Order	3 ft / Black L1 , Red L2 and Blue L3 Green ground
Voltaje	3 Phase 208~240/440~480V 50/60Hz	Recommended Hoist Protection Circuit Breaker AMPs and Type	Type D 50A at 220V and 30A at 460V
Altura de Izaje Estandar (Customizable)	40 ft / 12 m	Optional Load Chain Brand & Country of Origin	FEC Japan
Velocidad /min	10.63 ft @60Hz 2.70 mt @50Hz	Tipo de Cadena	G100 Nikel
Numero de Velocidades	1 Speed	Dimensiones de la Cadena	11.2 mm
Hoist Contactors Amps	25A	Caidas de Cadena	4
Hoist Contactor Brand	Schneider	Longitud de cadena	160
Hoist UL Components	UL Listed Contactors	Load Chain weight per foot [lbs]	1.83
Hoist Contactor Coil Voltage	24 V	Humedad	20%~90%
Clase de Servicio	H4/M5/2m/Class D	Temperatura	-4 ~ 104° F / -20 ~ 40° C
IEC Hoist IP Protection	IP55	Tipo Transmisión / Reductor	Spur gearbox
Protección IEC Motor	IP55	Reducer Lubrication Type	Oil
Pendant Control Yes No	Yes	Paint Specifications	Electrostatic Sprayed Plastic (ESP) Epoxy resins, Polyester Resins, Barium, Pigments
IEC Pendant Control Protection	IP66	Normas	ASME HST-1 , ASME B30.16 , EN60204-38
Pendant Control Emergency Stop	Yes	Standards Certified	CE
Pendant Control total Length	37 ft	Overload Protection	Overload Motor Clutch
Hoist Motor Power in KW	3+3	Hour Meter	Internal Working Hour Meter
Hoist Motor Brake Type and DC Voltage	DC99V/DC207V	Brake SKU	PWRX-2-20-PN.60.61
Hoist Motor Insulation Grade	F	Brake rectifiers-half-wave	PWRX-BKTF-HW
Potencia Total Watts	6000	Brake rectifiers-full-wave	PWRX-BKTF-FW

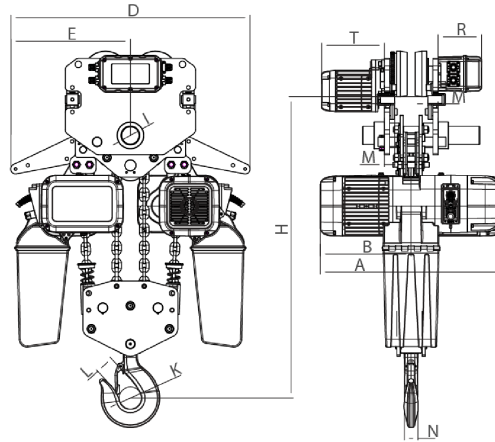

Rated load (t)	Type	Dimension (mm)													
		Minimum distance from the bottom of the track to the bottom hook: H	A	L	B	D	E	I	M	N	K	L	T	R	
10	PWRXT10-04	1045	700	3500-5500	350	920	460	70	39	48	85	80	242	167	

Peso & Dimensiones

A Altura Total	1200	Paquete 1 Altura	40 in / 101.6 cm
J Boca Gancho	85	Paquete 1 Peso Neto	638 lbs / 289 Kg
W Ancho	920	Paquete 1 Ancho	30 in / 76.2 cm
H Altura Muerta	1005	Paquete 1 Peso Bruto	682 lbs / 309 Kg
D Depth	700	Paquete 1 Profundidad	44 in / 111.76 cm
1st Package Type	Wood Crate		
Peso Total (sin cable o cadena)	345		
Peso Total	682 lbs / 310 Kg		

Detalles del Empaque

Referential Images / Imágenes Referenciales
Specifications may change without notice / las especificaciones pueden cambiar sin previo aviso