



1 ton Electric Chain Hoist Variable Speed 110V 1ø 60HZ

Características Esenciales

- 3 Años de Garantía, Servicio y Atención al Cliente en Chile

Especificaciones Técnicas

Capacidad de Carga	1 ton	Caidas de Cadena	1
Altura de Izaje Estandar (Customizable)	20 ft / 6 m	Longitud de cadena	20
Velocidad /min	ft @60Hz 0.8~7 mt @50Hz	Humedad	20%~90%
Numero de Velocidades	Variable Speed	Temperatura	-4 ~ 104° F / -20 ~ 40° C
Voltaje	1 Phase 110~120V 60Hz	Normas	ASME HST-1 , ASME B30.16 , EN60204-33
Potencia Total Watts	4000	Garantía	3 Year
Clase de Servicio	H4/M5/2m/Class D	Hoist VFD Power	4kW
Protección IEC Motor	IP55	Hoist VFD Brand	HUAYUAN
Control	Pendant Control IP66 and Industrial Wireless Control	Hoist Motor Power in KW	1.5
Voltaje del Control	24V	Hour Meter	Internal Working Hour Meter
Parada de Emergencia	Yes	Hoist Motor Insulation Grade	F
Tipo Transmisión / Reductor	Spur gearbox	IEC Hoist IP Protection	IP55
Tipo de Cadena	G100 Nikel	IEC Pendant Control Protection	IP66
Dimensiones de la Cadena	7.1 mm	Hoist Motor Brake Type and DC Voltage	DC170V

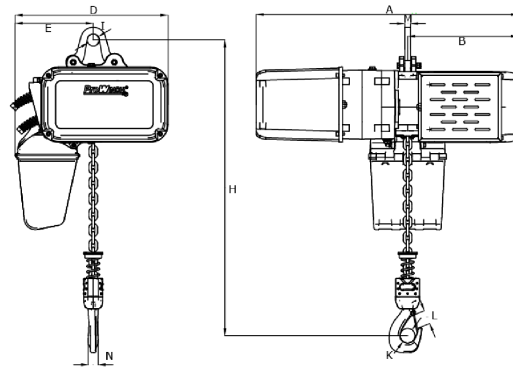

[Size list: mm]

Rated load (t)	Type	Minimum distance between hooks: H	A	B	D	E	I	M	N	K	L
1	PWRXF1-VS-110V	499	704.5	298	410	209	31	24	25	42	32
2-3	PWRXF2-3-VS-110V	540	780	348	463	263	45	20	35	52	42

Peso & Dimensiones

H Altura Muerta	516
J Boca Gancho	42
A Altura Total	455
Peso Total (sin cable o cadena)	86
D Depth	590
1st Package Type	Wood Crate
W Ancho	330
Peso Total	209 lbs / 95 Kg

Detalles del Empaque

Paquete 1 Peso Neto	101.64 lbs / 46 Kg
Paquete 1 Ancho	16 in / 40.64 cm
Paquete 1 Peso Bruto	209 lbs / 95 Kg
Paquete 1 Altura	26 in / 66.04 cm
Paquete 1 Profundidad	26 in / 66.04 cm

Referential Images / Imágenes Referenciales
Specifications may change without notice / las especificaciones pueden cambiar sin previo aviso

