



## 1 ton Electric Chain Hoist w/ Power Trolley 2 Speed 575V 3Ø 50/60HZ

### Características Esenciales

- 3 Años de Garantía, Servicio y Atención al Cliente en Chile

## Especificaciones Técnicas

|   |  |                                    |                                       |
|---|--|------------------------------------|---------------------------------------|
| <b>Capacidad de Carga</b>                       | 1 ton                                      | <b>Parada de Emergencia</b>        | Yes                                   |
| <b>Altura de Izaje Estandard (Customizable)</b> | 20 ft / 6 m                                | <b>Tipo Transmisión / Reductor</b> | Spur gearbox                          |
| <b>Velocidad /min</b>                           | 7.8/42.6 ft @60Hz<br>2/6.5 mt @50Hz        | <b>Tipo de Cadena</b>              | G100 Nickel                           |
| <b>Numero de Velocidades</b>                    | 2 Speed                                    | <b>Dimensiones de la Cadena</b>    | 7.1 mm                                |
| <b>Voltaje</b>                                  | 3 Phase 575v 50/60 Hz                      | <b>Caidas de Cadena</b>            | 1                                     |
| <b>Potencia Total Watts</b>                     | 1500                                       | <b>Longitud de cadena</b>          | 20                                    |
| <b>Clase de Servicio</b>                        | H4/M5/2m/Class D                           | <b>Humedad</b>                     | 20%~90%                               |
| <b>Protección IEC Motor</b>                     | IP55                                       | <b>Temperatura</b>                 | -4 ~ 104° F / -20 ~ 40° C             |
| <b>Control</b>                                  | Pendant Control IP66 and Optional Wireless | <b>Normas</b>                      | ASME HST-1 , ASME B30.16 , EN60204-33 |
| <b>Voltaje del Control</b>                      | 24V  | <b>Garantía</b>                    | 3 Year                                |

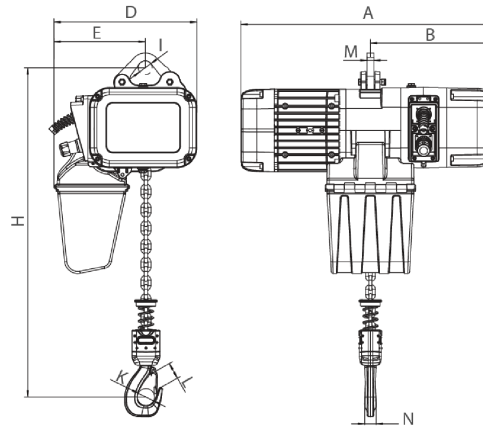

[Size list: mm]

| Rated load (t) | Type      | Minimum distance between hooks: H | A   | B   | D   | E   | I  | M  | N  | K  | L  |
|----------------|-----------|-----------------------------------|-----|-----|-----|-----|----|----|----|----|----|
| 1              | PWRXF1-01 | 455                               | 590 | 276 | 330 | 210 | 32 | 16 | 25 | 42 | 32 |
| 2              | PWRXF2-01 | 550                               | 590 | 276 | 330 | 210 | 38 | 20 | 35 | 52 | 42 |
| 3              | PWRXF3-01 | 560                               | 695 | 350 | 420 | 265 | 45 | 20 | 34 | 59 | 48 |
| 5              | PWRXF5-02 | 675                               | 695 | 350 | 420 | 307 | 55 | 28 | 44 | 60 | 48 |

## Peso & Dimensiones

|  |                 |                              |                    |
|--|-----------------|------------------------------|--------------------|
| <b>H Altura Muerta</b>                 | 516             | <b>Paquete 1 Peso Neto</b>   | 101.64 lbs / 46 Kg |
| <b>W Ancho</b>                         | 330             | <b>Paquete 1 Ancho</b>       | 16 in / 40.64 cm   |
| <b>A Altura Total</b>                  | 455             | <b>Paquete 1 Peso Bruto</b>  | 209 lbs / 95 Kg    |
| <b>J Boca Gancho</b>                   | 42              | <b>Paquete 1 Altura</b>      | 26 in / 66.04 cm   |
| <b>D Depth</b>                         | 590             | <b>Paquete 1 Profundidad</b> | 26 in / 66.04 cm   |
| <b>Peso Total (sin cable o cadena)</b> | 86              |                              |                    |
| <b>Peso Total</b>                      | 209 lbs / 95 Kg |                              |                    |

## Detalles del Empaque

Referential Images / Imágenes Referenciales

Specifications may change without notice / las especificaciones pueden cambiar sin previo aviso