



## 1 ton Electric Chain Hoist 2 Speed 208~240V / 440~480V 3 $\phi$ 1/2 60HZ

### Características Esenciales

- 3 Años de Garantía, Servicio y Atención al Cliente en Chile

### Especificaciones Técnicas

Capacidad de Carga	1 ton	Longitud de cadena	20
Altura de Izaje Estandar (Customizable)	20 ft / 6 m	Humedad	20%~90%
Velocidad /min	25.60 ft @60Hz 6.50 mt @50Hz	Temperatura	-4 ~ 104° F / -20 ~ 40° C
Numero de Velocidades	2 Speed	Normas	ASME HST-1 , ASME B30.16 , EN60204-33
Voltaje	3 Phase 208~240/440~480V 50/60Hz	Garantía	3 Year
Potencia Total Watts	1500	Hoist Motor Power in KW	1.5
Clase de Servicio	H4/M5/2m/Class D	Hour Meter	Internal Working Hour Meter
Protección IEC Motor	IP55	Hoist Motor Insulation Grade	F
Control	Pendant Control IP66 and Optional Wireless	Hoist Contactor Coil Voltage	24 V
Voltaje del Control	24V	Hoist Contactors Amps	18A
Parada de Emergencia	Yes	Hoist Contactor Brand	Schneider
Tipo Transmisión / Reductor	Spur gearbox	IEC Hoist IP Protection	IP55
Tipo de Cadena	G100 Nikel	IEC Pendant Control Protection	IP66
Dimensiones de la Cadena	7.1 mm	Hoist Motor Brake Type and DC Voltage	DC99V/DC207V
Caidas de Cadena	1		

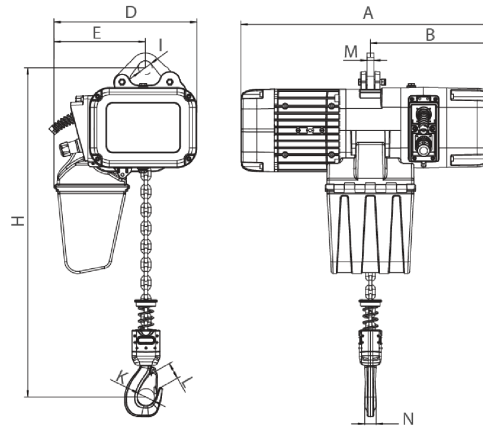

[Size list: mm]

Rated load (t)	Type	Minimum distance between hooks: H	A	B	D	E	I	M	N	K	L
1	PWRXF1-01	455	590	276	330	210	32	16	25	42	32
2	PWRXF2-01	550	590	276	330	210	38	20	35	52	42
3	PWRXF3-01	560	695	350	420	265	45	20	34	59	48
5	PWRXF5-02	675	695	350	420	307	55	28	44	60	48

## Peso & Dimensiones

<b>H Altura Muerta</b>	516	<b>Paquete 1 Peso Neto</b>	101.64 lbs / 46 Kg
<b>J Boca Gancho</b>	42	<b>Paquete 1 Ancho</b>	16 in / 40.64 cm
<b>A Altura Total</b>	455	<b>Paquete 1 Peso Bruto</b>	209 lbs / 95 Kg
<b>Peso Total (sin cable o cadena)</b>	86	<b>Paquete 1 Altura</b>	26 in / 66.04 cm
<b>D Depth</b>	590	<b>Paquete 1 Profundidad</b>	26 in / 66.04 cm
<b>1st Package Type</b>	Wood Crate		
<b>W Ancho</b>	330		
<b>Peso Total</b>	209 lbs / 95 Kg		

## Detalles del Empaque

Referential Images / Imágenes Referenciales  
Specifications may change without notice / las especificaciones pueden cambiar sin previo aviso

