



## **1 ton Electric Chain Hoist 1 Speed 380V 3ø 50HZ**

### **Características Esenciales**

- 3 Años de Garantía, Servicio y Atención al Cliente en Chile

## Especificaciones Técnicas

<b>Capacidad de Carga</b>	1 ton	<b>Power Cord Length and Phase Order</b>	3 ft / Red L1, White L2 and Black L3, Green ground
<b>Voltaje</b>	3 Phase 380V 50Hz	<b>Recommended Hoist Protection Circuit Breaker AMPs and Type</b>	Type D 15A
<b>Altura de Izaje Estandar (Customizable)</b>	20 ft / 6 m	<b>Optional Load Chain Brand &amp; Country of Origin</b>	FEC Japan
<b>Velocidad /min</b>	25.59 ft @60Hz 6.50 mt @50Hz	<b>Tipo de Cadena</b>	G100 Nikel
<b>Numero de Velocidades</b>	1 Speed	<b>Dimensiones de la Cadena</b>	7.1 mm
<b>Hoist Contactors Amps</b>	18A	<b>Caidas de Cadena</b>	1
<b>Hoist Contactor Brand</b>	Schneider	<b>Longitud de cadena</b>	20
<b>Hoist Contactor Coil Voltage</b>	24 V	<b>Load Chain weight per foot [lbs]</b>	0.58
<b>Clase de Servicio</b>	H4/M5/2m/Class D	<b>Humedad</b>	20%~90%
<b>IEC Hoist IP Protection</b>	IP55	<b>Temperatura</b>	-4 ~ 104° F / -20 ~ 40° C
<b>Protección IEC Motor</b>	IP55	<b>Tipo Transmisión / Reductor</b>	Spur gearbox
<b>Pendant Control Yes No</b>	Yes	<b>Reducer Lubrication Type</b>	Oil
<b>IEC Pendant Control Protection</b>	IP66	<b>Paint Specifications</b>	Electrostatic Sprayed Plastic (ESP) Epoxy resins, Polyester Resins, Barium, Pigments
<b>Pendant Control Emergency Stop</b>	Yes	<b>Normas</b>	ASME HST-1 , ASME B30.16 , EN60204-33
<b>Pendant Control total Length</b>	17 ft	<b>Standards Certified</b>	CE
<b>Hoist Motor Power in KW</b>	1.5	<b>Overload Protection</b>	Overload Motor Clutch
<b>Hoist Motor Brake Type and DC Voltage</b>	DC170V	<b>Hour Meter</b>	Internal Working Hour Meter
<b>Hoist Motor Insulation Grade</b>	F	<b>Brake SKU</b>	PWRX-1-PN.60.61
<b>Potencia Total Watts</b>	1500	<b>Brake rectifiers-half-wave</b>	PWRX-BKTF-HW

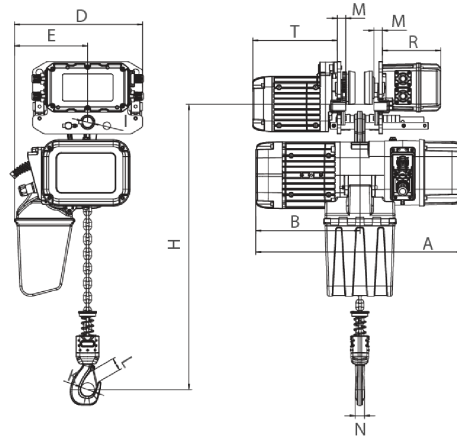

Rated load (t)	Type	Dimension (mm)													
		Minimum distance from the bottom of the track to the bottom hook: H	A	L	B	D	E	I	M	N	K	L	T	R	
1	PWRXT1-01	473	440	3500-5500	285	210	20	105	140						
2	PWRXT2-01	516	590		276	368	210	31	24	25	42	32	242	167	
3	PWRXT3-01	600	681		350	422	264	36	28	35	52	42	242	167	
5	PWRXT5-02	645	681		350	478	307	43	30	34	59	48	242	167	

## Peso & Dimensiones

<b>A Altura Total</b>	455	<b>Paquete 1 Altura</b>	26 in / 66.04 cm
<b>J Boca Gancho</b>	42	<b>Paquete 1 Peso Neto</b>	101.64 lbs / 46 Kg
<b>W Ancho</b>	330	<b>Paquete 1 Ancho</b>	16 in / 40.64 cm
<b>H Altura Muerta</b>	516	<b>Paquete 1 Peso Bruto</b>	121 lbs / 55 Kg
<b>D Depth</b>	590	<b>Paquete 1 Profundidad</b>	26 in / 66.04 cm
<b>1st Package Type</b>	Wood Crate		
<b>Peso Total (sin cable o cadena)</b>	90		
<b>Peso Total</b>	121 lbs / 55 Kg		

## Detalles del Empaque

Referential Images / Imágenes Referenciales  
Specifications may change without notice / las especificaciones pueden cambiar sin previo aviso