



1 ton Electric Chain Hoist 1 Speed 208~240V / 440~480V 3ph 60HZ

Características Esenciales

- 3 Años de Garantía, Servicio y Atención al Cliente en Chile

1 ton Electric Chain Hoist 1 Speed 208~240V / 440~480V 3ø 60HZ 20ft G100 Nickel Duty H4/M5

Especificaciones Técnicas

| | | | |
|--|----------------------------------|---|--|
| Capacidad de Carga | 1 ton | Power Cord Length and Phase Order | 3 ft / Black L1 , Red L2 and Blue L3 Green ground |
| Voltaje | 3 Phase 208~240/440~480V 50/60Hz | Recommended Hoist Protection Circuit Breaker AMPs and Type | Type D 20A at 220V and 15A at 460V |
| Altura de Izaje Estandar (Customizable) | 20 ft / 6 m | Optional Load Chain Brand & Country of Origin | FEC Japan |
| Velocidad /min | 25.60 ft @60Hz 6.50 mt @50Hz | Tipo de Cadena | G100 Nikel |
| Numero de Velocidades | 1 Speed | Dimensiones de la Cadena | 7.1 mm |
| Hoist Contactors Amps | 18A | Caidas de Cadena | 1 |
| Hoist Contactor Brand | Schneider | Longitud de cadena | 20 |
| Hoist UL Components | UL Listed Contactors | Load Chain weight per foot [lbs] | 0.74 |
| Hoist Contactor Coil Voltage | 24 V | Humedad | 20%~90% |
| Clase de Servicio | H4/M5/2m/Class D | Temperatura | -4 ~ 104° F / -20 ~ 40° C |
| IEC Hoist IP Protection | IP55 | Tipo Transmisión / Reductor | Spur gearbox |
| Protección IEC Motor | IP55 | Reducer Lubrication Type | Oil |
| Pendant Control Yes No | Yes | Paint Specifications | Electrostatic Sprayed Plastic (ESP) Epoxy resins, Polyester Resins, Barium, Pigments |
| IEC Pendant Control Protection | IP66 | Normas | ASME HST-1 , ASME B30.16 , EN60204-33 |
| Pendant Control Emergency Stop | Yes | Standards Certified | CE |
| Pendant Control total Length | 17 ft | Overload Protection | Overload Motor Clutch |
| Hoist Motor Power in KW | 1.5 | Hour Meter | Internal Working Hour Meter |
| Hoist Motor Brake Type and DC Voltage | DC99V/DC207V | Brake SKU | PWRX-1-PN.60.61 |
| Hoist Motor Insulation Grade | F | Brake rectifiers-half-wave | PWRX-BKTF-HW |
| Potencia Total Watts | 1500 | Brake rectifiers-full-wave | PWRX-BKTF-FW |

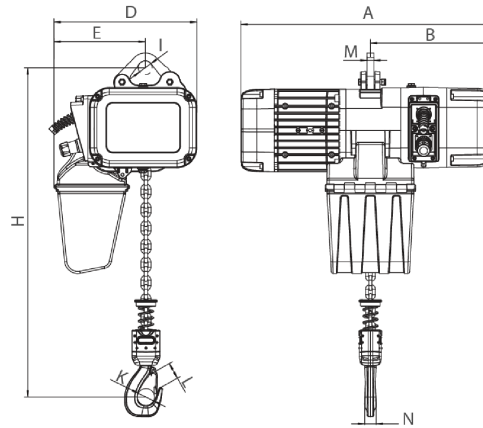

[Size list: mm]

| Rated load (t) | Type | Minimum distance between hooks: H | A | B | D | E | I | M | N | K | L |
|----------------|-----------|-----------------------------------|-----|-----|-----|-----|----|----|----|----|----|
| 1 | PWRXF1-01 | 455 | 590 | 276 | 330 | 210 | 32 | 16 | 25 | 42 | 32 |
| 2 | PWRXF2-01 | 550 | 590 | 276 | 330 | 210 | 38 | 20 | 35 | 52 | 42 |
| 3 | PWRXF3-01 | 560 | 695 | 350 | 420 | 265 | 45 | 20 | 34 | 59 | 48 |
| 5 | PWRXF5-02 | 675 | 695 | 350 | 420 | 307 | 55 | 28 | 44 | 60 | 48 |

Peso & Dimensiones

| | | | |
|--|-----------------|------------------------------|--------------------|
| A Altura Total | 455 | Paquete 1 Altura | 28 in / 71.12 cm |
| J Boca Gancho | 42 | Paquete 1 Peso Neto | 101.64 lbs / 46 Kg |
| W Ancho | 330 | Paquete 1 Ancho | 16 in / 40.64 cm |
| H Altura Muerta | 516 | Paquete 1 Peso Bruto | 150 lbs / 68 Kg |
| D Depth | 590 | Paquete 1 Profundidad | 26 in / 66.04 cm |
| 1st Package Type | Wood Crate | | |
| Peso Total (sin cable o cadena) | 86 | | |
| Peso Total | 150 lbs / 69 Kg | | |

Detalles del Empaque

Referential Images / Imágenes Referenciales
Specifications may change without notice / las especificaciones pueden cambiar sin previo aviso

