



1/2 ton Electric Chain Hoist Variable Speed 380V 3ø 50~60HZ

Características Esenciales

- 3 Años de Garantía, Servicio y Atención al Cliente en Chile

Especificaciones Técnicas

Paint Specifications	Electrostatic Sprayed Plastic (ESP) Epoxy resins, Polyester Resins, Barium, Pigments	Potencia Total Watts	1500
Standards Certified	CE	Clase de Servicio	H4/M5/2m/Class D
Brake rectifiers-half-wave	PWRX-BKTF-HW	Tipo de Motor	TEFC
VFD Model	Z230	Protección IEC Motor	IP55
Brake Resistor Kw	0.3Kw	Control	Pendant Control IP66 and Optional Wireless
Pendant Control Yes No	Included	Voltaje del Control	24V
Pendant Control Emergency Stop	Yes	Parada de Emergencia	Yes
Overload Protection	Overload Motor Clutch	Tipo Transmisión / Reductor	Spur gearbox
Brake SKU	PWRX-0.25-0.5-PN.4.11	Tipo de Cadena	G100 Nikel
Power Cord Length and Phase Order	3 ft / Red L1, White L2 and Black L3, Green ground	Dimensiones de la Cadena	6.3mm
Recommended Hoist Protection Circuit Breaker AMPs and Type	Type D 10A	Caidas de Cadena	1
Optional Load Chain Brand & Country of Origin	FEC Japan	Longitud de cadena	13
Capacidad de Carga	1/2 ton	Humedad	20%~90%
Altura de Izaje Estandar (Customizable)	13 ft / 4 m	Temperatura	-4 ~ 104° F / -20 ~ 40° C
Velocidad /min	ft @60Hz 1~8 mt @50Hz	Normas	ASME HST-1 , ASME B30.16 , EN60204-37
Numero de Velocidades	Variable Speed	Garantía	3 Year
Voltaje	3 Phase 380V 50Hz		

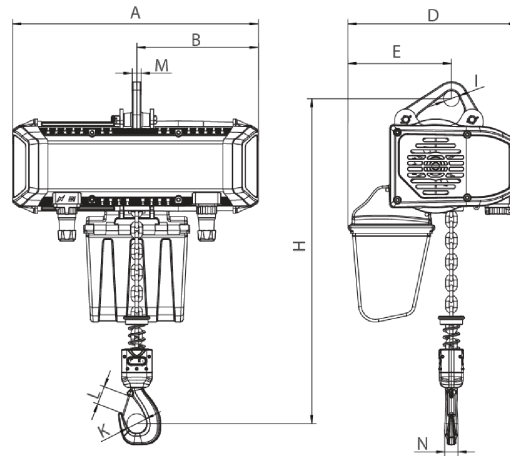

[Size list: mm]

Rated load (t)	Type	Minimum distance between hooks: H	A	B	D	E	I	M	N	K	L
0-25-0-5	PWRXF0-25-0-5-VS	399	447	217	337	179	31	16	20	35	31

Peso & Dimensiones

H Altura Muerta	396	Paquete 1 Peso Neto	72.16 lbs / 33 Kg
W Ancho	305	Paquete 1 Ancho	15 in / 38.1 cm
A Altura Total	396	Paquete 1 Peso Bruto	85.8 lbs / 39 Kg
J Boca Gancho	35	Paquete 1 Altura	20 in / 50.8 cm
D Depth	440	Paquete 1 Profundidad	20 in / 50.8 cm
Peso Total (sin cable o cadena)	64		
Peso Total	85.8 lbs / 39 Kg		

Detalles del Empaque

Referential Images / Imágenes Referenciales

Specifications may change without notice / las especificaciones pueden cambiar sin previo aviso