



1/2 ton Electric Chain Hoist Variable Speed 220V 1ø 50~60HZ

Características Esenciales

- 3 Años de Garantía, Servicio y Atención al Cliente en Chile

Especificaciones Técnicas

Capacidad de Carga	1/2 ton	Power Cord Length and Phase Order	3 ft / Black L1, White, Green ground
Voltaje	1 Phase 220~240V 50/60Hz	Recommended Hoist Protection Circuit Breaker AMPs and Type	Type D 10A
Altura de Izaje Estandar (Customizable)	13 ft / 4 m	Optional Load Chain Brand & Country of Origin	FEC Japan
Velocidad /min	ft @60Hz 1~8 mt @50Hz	Tipo de Cadena	G100 Nikel
Numero de Velocidades	Variable Speed	Dimensiones de la Cadena	6.3mm
Hoist VFD Power	1.5kW	Caidas de Cadena	1
Hoist VFD Brand	HUAYUAN	Longitud de cadena	13
VFD Model	Z230	Load Chain weight per foot [lbs]	0.58
Brake Resistor Kw	0.3Kw	Humedad	20%~90%
Clase de Servicio	H4/M5/2m/Class D	Temperatura	-4 ~ 104° F / -20 ~ 40° C
IEC Hoist IP Protection	IP55	Tipo Transmisión / Reductor	Spur gearbox
Protección IEC Motor	IP55	Reducer Lubrication Type	Oil
Pendant Control Yes No	Yes	Paint Specifications	Electrostatic Sprayed Plastic (ESP) Epoxy resins, Polyester Resins, Barium, Pigments
IEC Pendant Control Protection	IP66	Normas	ASME HST-1 , ASME B30.16 , EN60204-37
Pendant Control Emergency Stop	Yes	Standards Certified	CE
Pendant Control total Length	10 ft	Overload Protection	Overload Motor Clutch
Hoist Motor Power in KW	0.75	Hour Meter	Internal Working Hour Meter
Hoist Motor Brake Type and DC Voltage	DC170V	Brake SKU	PWRX-0.25-0.5-PN.4.11
Hoist Motor Insulation Grade	F	Brake rectifiers-half-wave	PWRX-BKTF-HW
Potencia Total Watts	1500		

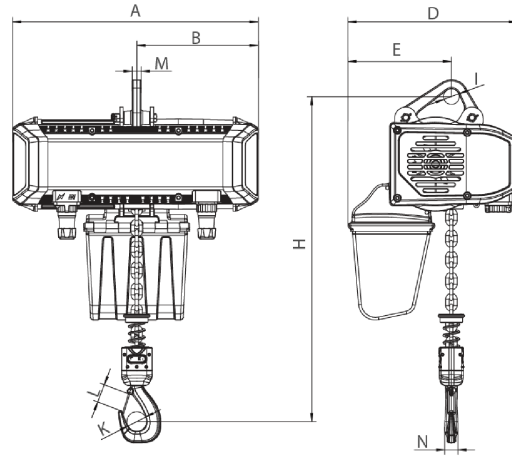

[Size list: mm]

Rated load (t)	Type	Minimum distance between hooks: H	A	B	D	E	I	M	N	K	L
0-25-0-5	PWRXF0-25-0-5-VS	399	447	217	337	179	31	16	20	35	31

Peso & Dimensiones

A Altura Total	396
J Boca Gancho	35
W Ancho	305
H Altura Muerta	396
D Depth	440
1st Package Type	Wood Crate
Peso Total (sin cable o cadena)	64
Peso Total	85.8 lbs / 39 Kg

Detalles del Empaque

Paquete 1 Altura	20 in / 50.8 cm
Paquete 1 Peso Neto	72.16 lbs / 33 Kg
Paquete 1 Ancho	15 in / 38.1 cm
Paquete 1 Peso Bruto	85.8 lbs / 39 Kg
Paquete 1 Profundidad	20 in / 50.8 cm

Referential Images / Imágenes Referenciales
Specifications may change without notice / las especificaciones pueden cambiar sin previo aviso