



## 1/2 ton Electric Chain Hoist Variable Speed 110V 1ø 60HZ

### Características Esenciales

- 3 Años de Garantía, Servicio y Atención al Cliente en Chile

### Especificaciones Técnicas

<b>Capacidad de Carga</b>	1/2 ton	<b>Caidas de Cadena</b>	1
<b>Altura de Izaje Estandar (Customizable)</b>	13 ft / 4 m	<b>Longitud de cadena</b>	13
<b>Velocidad /min</b>	ft @60Hz 1~8 mt @50Hz	<b>Humedad</b>	20%~90%
<b>Numero de Velocidades</b>	Variable Speed	<b>Temperatura</b>	-4 ~ 104° F / -20 ~ 40° C
<b>Voltaje</b>	1 Phase 110~120V 60Hz	<b>Normas</b>	ASME HST-1 , ASME B30.16 , EN60204-37
<b>Potencia Total Watts</b>	1500	<b>Garantía</b>	3 Year
<b>Clase de Servicio</b>	H4/M5/2m/Class D	<b>Hoist VFD Power</b>	1.5kW
<b>Protección IEC Motor</b>	IP55	<b>Hoist VFD Brand</b>	HUAYUAN
<b>Control</b>	Pendant Control IP66 and Industrial Wireless Control	<b>Hoist Motor Power in KW</b>	0.75
<b>Voltaje del Control</b>	24V	<b>Hour Meter</b>	Internal Working Hour Meter
<b>Parada de Emergencia</b>	Yes	<b>Hoist Motor Insulation Grade</b>	F
<b>Tipo Transmisión / Reductor</b>	Spur gearbox	<b>IEC Hoist IP Protection</b>	IP55
<b>Tipo de Cadena</b>	G100 Nikel	<b>IEC Pendant Control Protection</b>	IP66
<b>Dimensiones de la Cadena</b>	6.3mm	<b>Hoist Motor Brake Type and DC Voltage</b>	DC170V

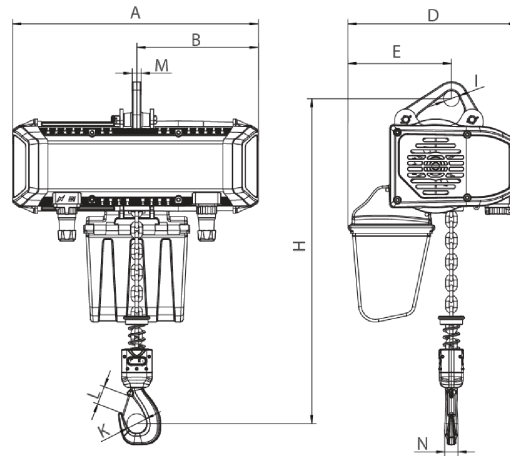

[Size list: mm]

Rated load (t)	Type	Minimum distance between hooks: H	A	B	D	E	I	M	N	K	L
0-25-0-5	PWRXF0-25-0-5-VS	399	447	217	337	179	31	16	20	35	31

## Peso & Dimensiones

<b>H Altura Muerta</b>	396	<b>Paquete 1 Peso Neto</b>	72.16 lbs / 33 Kg
<b>J Boca Gancho</b>	35	<b>Paquete 1 Ancho</b>	15 in / 38.1 cm
<b>A Altura Total</b>	396	<b>Paquete 1 Peso Bruto</b>	85.8 lbs / 39 Kg
<b>Peso Total (sin cable o cadena)</b>	64	<b>Paquete 1 Altura</b>	20 in / 50.8 cm
<b>D Depth</b>	440	<b>Paquete 1 Profundidad</b>	20 in / 50.8 cm
<b>1st Package Type</b>	Wood Crate		
<b>W Ancho</b>	305		
<b>Peso Total</b>	85.8 lbs / 39 Kg		

## Detalles del Empaque

Referential Images / Imágenes Referenciales

Specifications may change without notice / las especificaciones pueden cambiar sin previo aviso