



## **1/2 ton Electric Chain Hoist 2 Speed 208~240V 3Å, 60HZ**

### **Características Esenciales**

- 3 Años de Garantía, Servicio y Atención al Cliente en Chile

## Especificaciones Técnicas

<b>Capacidad de Carga</b>	1/2 ton	<b>Recommended Hoist Protection Circuit Breaker AMPs and Type</b>	Type D 15A at 220V and 10A at 460V
<b>Voltaje</b>	3 Phase 208~240V	<b>Optional Load Chain Brand &amp; Country of Origin</b>	FEC Japan
<b>Velocidad /min</b>	31.49 ft @60Hz mt @50Hz	<b>Tipo de Cadena</b>	G100 Nickel
<b>Numero de Velocidades</b>	2 Speed	<b>Dimensiones de la Cadena</b>	6.3mm
<b>Hoist Contactors Amps</b>	10A	<b>Caidas de Cadena</b>	1
<b>Hoist Contactor Brand</b>	Schneider	<b>Longitud de cadena</b>	13
<b>Hoist UL Components</b>	UL Listed Contactors	<b>Load Chain weight per foot [lbs]</b>	0.58
<b>Hoist Contactor Coil Voltage</b>	48V	<b>Humedad</b>	20%~90%
<b>Clase de Servicio</b>	H4/M5/2m/Class D	<b>Temperatura</b>	-4 ~ 104° F / -20 ~ 40° C
<b>IEC Hoist IP Protection</b>	IP55	<b>Tipo Transmisión / Reductor</b>	Spur gearbox
<b>Protección IEC Motor</b>	IP55	<b>Reducer Lubrication Type</b>	Oil
<b>Pendant Control Yes No</b>	Yes	<b>Paint Specifications</b>	Electrostatic Sprayed Plastic (ESP) Epoxy resins, Polyester Resins, Barium, Pigments
<b>IEC Pendant Control Protection</b>	IP66	<b>Normas</b>	ASME HST-1 , ASME B30.16 , EN60204-37
<b>Pendant Control Emergency Stop</b>	Yes	<b>Standards Certified</b>	CE
<b>Pendant Control total Length</b>	10 ft	<b>Overload Protection</b>	Overload Motor Clutch
<b>Hoist Motor Power in KW</b>	0.75	<b>Hour Meter</b>	Internal Working Hour Meter
<b>Hoist Motor Brake Type and DC Voltage</b>	DC99V	<b>Brake SKU</b>	PWRX-0.25-0.5-PN.4.11
<b>Hoist Motor Insulation Grade</b>	F	<b>Brake rectifiers-half-wave</b>	PWRX-BKTF-HW
<b>Potencia Total Watts</b>	750	<b>Brake rectifiers-full-wave</b>	PWRX-BKTF-FW
<b>Power Cord Length and Phase Order</b>	3 ft / Black L1 , Red L2 and Blue L3 L3□Green ground		

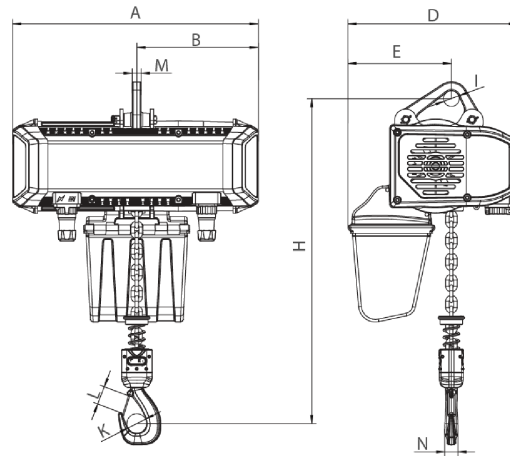

[Size list: mm]

Rated load (t)	Type	Minimum distance between hooks: H	A	B	D	E	I	M	N	K	L
0-25-0-5	PWRXF0-25-0-5-VS	399	447	217	337	179	31	16	20	35	31

## Peso & Dimensiones

<b>A Altura Total</b>	396
<b>J Boca Gancho</b>	35
<b>W Ancho</b>	305
<b>H Altura Muerta</b>	396
<b>D Depth</b>	440
<b>1st Package Type</b>	Wood Crate
<b>Peso Total (sin cable o cadena)</b>	58
<b>Peso Total</b>	79.2 lbs / 36 Kg

## Detalles del Empaque

<b>Paquete 1 Altura</b>	20 in / 50.8 cm
<b>Paquete 1 Peso Neto</b>	65.56 lbs / 30 Kg
<b>Paquete 1 Ancho</b>	15 in / 38.1 cm
<b>Paquete 1 Peso Bruto</b>	79.2 lbs / 36 Kg
<b>Paquete 1 Profundidad</b>	20 in / 50.8 cm

Referential Images / Imágenes Referenciales  
Specifications may change without notice / las especificaciones pueden cambiar sin previo aviso