



## 1/2 ton Electric Chain Hoist 1 Speed 380V 3ø 50HZ 13ft G100 Nickel Duty H4/M5

### Características Esenciales

- 3 Años de Garantía, Servicio y Atención al Cliente en Chile

### Especificaciones Técnicas

Capacidad de Carga	1/2 ton	Longitud de cadena	13
Altura de Izaje Estandar (Customizable)	13 ft / 4 m	Humedad	20%~90%
Velocidad /min	31.49 ft @60Hz 8 mt @50Hz	Temperatura	-4 ~ 104° F / -20 ~ 40° C
Numero de Velocidades	1 Speed	Normas	ASME HST-1 , ASME B30.16 , EN60204-37
Voltaje	3 Phase 380V 50Hz	Garantía	3 Year
Potencia Total Watts	750	Hoist UL Components	UL Listed Contactors
Clase de Servicio	H4/M5/2m/Class D	Hoist Motor Power in KW	0.75
Protección IEC Motor	IP55	Hour Meter	Internal Working Hour Meter
Control	Pendant Control IP66 and Optional Wireless	Hoist Motor Insulation Grade	F
Voltaje del Control	48V	Hoist Contactor Coil Voltage	48V
Parada de Emergencia	Yes	Hoist Contactors Amps	10A
Tipo Transmisión / Reductor	Spur gearbox	Hoist Contactor Brand	Schneider
Tipo de Cadena	G100 Nickel	IEC Hoist IP Protection	IP55
Dimensiones de la Cadena	6.3mm	IEC Pendant Control Protection	IP66
Caidas de Cadena	1	Hoist Motor Brake Type and DC Voltage	DC170V

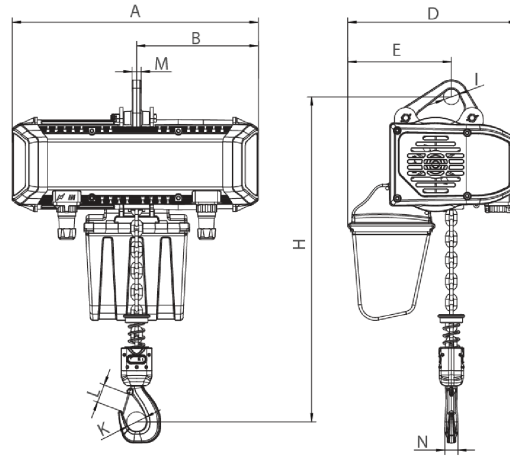

[Size list: mm]

Rated load (t)	Type	Minimum distance between hooks: H	A	B	D	E	I	M	N	K	L
0.25	PWRXF0.25-01	385	440	218	305	186	28	16	20	35	31
0.5	PWRXF0.5-01	385	440	218	305	186	28	16	20	35	31

## Peso & Dimensiones

H Altura Muerta	396
J Boca Gancho	35
A Altura Total	396
Peso Total (sin cable o cadena)	56
D Depth	440
1st Package Type	Wood Crate
W Ancho	305
Peso Total	74.8 lbs / 34 Kg

## Detalles del Empaque

Paquete 1 Peso Neto	61.16 lbs / 28 Kg
Paquete 1 Ancho	15 in / 38.1 cm
Paquete 1 Peso Bruto	74.8 lbs / 34 Kg
Paquete 1 Altura	20 in / 50.8 cm
Paquete 1 Profundidad	20 in / 50.8 cm

Referential Images / Imágenes Referenciales  
Specifications may change without notice / las especificaciones pueden cambiar sin previo aviso