



1/4 ton Electric Chain Hoist Variable Speed 380V 3ø 50~60HZ 13ft G100 Nickel Duty H4/M5

Características Esenciales

- 3 Años de Garantía, Servicio y Atención al Cliente en Chile

Especificaciones Técnicas

Capacidad de Carga	1/4 ton	Caidas de Cadena	1
Altura de Izaje Estandar (Customizable)	13 ft / 4 m	Longitud de cadena	13
Velocidad /min	ft @60Hz 1.5~9.6 mt @50Hz	Humedad	20%~90%
Numero de Velocidades	Variable Speed	Temperatura	-4 ~ 104° F / -20 ~ 40° C
Voltaje	3 Phase 380V 50Hz	Normas	ASME HST-1 , ASME B30.16 , EN60204-36
Potencia Total Watts	1500	Garantía	3 Year
Clase de Servicio	H4/M5/2m/Class D	Hoist VFD Power	1.5kW
Protección IEC Motor	IP55	Hoist VFD Brand	HUAYUAN
Control	Pendant Control IP66 and Optional Wireless	Hoist Motor Power in KW	0.5
Voltaje del Control	24V	Hour Meter	Internal Working Hour Meter
Parada de Emergencia	Yes	Hoist Motor Insulation Grade	F
Tipo Transmisión / Reductor	Spur gearbox	IEC Hoist IP Protection	IP55
Tipo de Cadena	G100 Nickel	IEC Pendant Control Protection	IP66
Dimensiones de la Cadena	5mm	Hoist Motor Brake Type and DC Voltage	DC170V

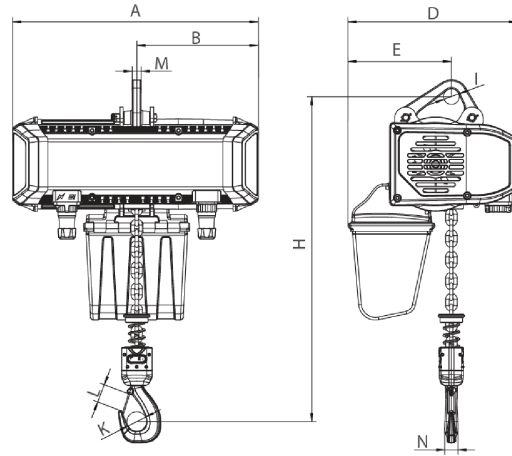

[Size list: mm]

Rated load (t)	Type	Minimum distance between hooks: H	A	B	D	E	I	M	N	K	L
0-25-0-5	PWRXF0-25-0-5-VS	399	447	217	337	179	31	16	20	35	31

Peso & Dimensiones

H Altura Muerta	385	Paquete 1 Peso Neto	72.16 lbs / 33 Kg
J Boca Gancho	35	Paquete 1 Ancho	15 in / 38.1 cm
A Altura Total	385	Paquete 1 Peso Bruto	85.8 lbs / 39 Kg
Peso Total (sin cable o cadena)	67	Paquete 1 Altura	20 in / 50.8 cm
D Depth	440	Paquete 1 Profundidad	20 in / 50.8 cm
1st Package Type	Wood Crate		
W Ancho	305		
Peso Total	85.8 lbs / 39 Kg		

Detalles del Empaque

Referential Images / Imágenes Referenciales

Specifications may change without notice / las especificaciones pueden cambiar sin previo aviso