



## 1/4 ton Electric Chain Hoist 2 Speed 208~240V 3Ø 60HZ 13ft G100 Nickel Duty H4/M5

### Características Esenciales

- 3 Años de Garantía, Servicio y Atención al Cliente en Chile

### Especificaciones Técnicas

Capacidad de Carga	1/4 ton	Longitud de cadena	13
Altura de Izaje Estandar (Customizable)	13 ft / 4 m	Humedad	20%~90%
Velocidad /min	37.79 ft @60Hz mt @50Hz	Temperatura	-4 ~ 104° F / -20 ~ 40° C
Numero de Velocidades	2 Speed	Normas	ASME HST-1 , ASME B30.16 , EN60204-36
Voltaje	3 Phase 208~240V 50/60Hz	Garantía	3 Year
Potencia Total Watts	500	Hoist UL Components	UL Listed Contactors
Clase de Servicio	H4/M5/2m/Class D	Hoist Motor Power in KW	0.5
Protección IEC Motor	IP55	Hour Meter	Internal Working Hour Meter
Control	Pendant Control IP66 and Optional Wireless	Hoist Motor Insulation Grade	F
Voltaje del Control	48V	Hoist Contactor Coil Voltage	48V
Parada de Emergencia	Yes	Hoist Contactors Amps	10A
Tipo Transmisión / Reductor	Spur gearbox	Hoist Contactor Brand	Schneider
Tipo de Cadena	G100 Nickel	IEC Hoist IP Protection	IP55
Dimensiones de la Cadena	5mm	IEC Pendant Control Protection	IP66
Caidas de Cadena	1	Hoist Motor Brake Type and DC Voltage	DC99V

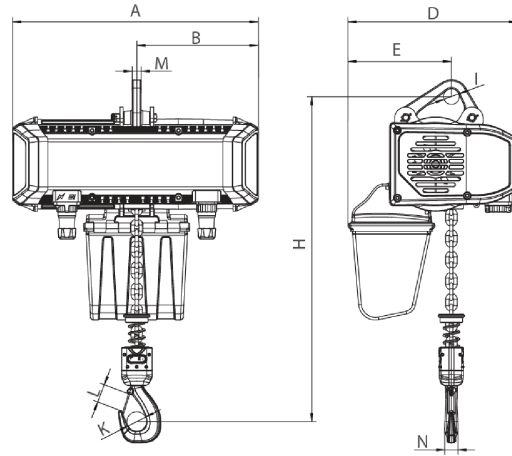

[Size list: mm]

Rated load (t)	Type	Minimum distance between hooks: H	A	B	D	E	I	M	N	K	L
0-25-0-5	PWRXF0-25-0-5-VS	399	447	217	337	179	31	16	20	35	31

## Peso & Dimensiones

<b>H Altura Muerta</b>	385	<b>Paquete 1 Peso Neto</b>	65.56 lbs / 30 Kg
<b>J Boca Gancho</b>	35	<b>Paquete 1 Ancho</b>	15 in / 38.1 cm
<b>A Altura Total</b>	385	<b>Paquete 1 Peso Bruto</b>	79.2 lbs / 36 Kg
<b>Peso Total (sin cable o cadena)</b>	60	<b>Paquete 1 Altura</b>	20 in / 50.8 cm
<b>D Depth</b>	440	<b>Paquete 1 Profundidad</b>	20 in / 50.8 cm
<b>1st Package Type</b>	Wood Crate		
<b>W Ancho</b>	305		
<b>Peso Total</b>	79.2 lbs / 36 Kg		

## Detalles del Empaque

Referential Images / Imágenes Referenciales

Specifications may change without notice / las especificaciones pueden cambiar sin previo aviso