

Tecle Cadena Neumatico 25 Tons - 16 metros de Izaje - Cadena RUD G80

Características Esenciales

- 25 Tons Pneumatic Chain Hoist - Heavy Duty - Explosion Proof
- RUD G80 chain made in Germany - 19.5 meters lifting height (other heights available upon request)
- Includes: Overload Protection - Slip Clutch / Failsafe Automatic Internal Break / Pendant Control with emergency stop (9 meters) / Chain containers
- Meets and exceeds ASME B30.16 / HST-5 standards / Load Test at 130% SWL / ATEX Directive
- 3 Años de Garantía, Servicio y Atención al Cliente en Chile

Especificaciones Técnicas

Capacidad de Carga	25 Ton	Parada de Emergencia	Yes
Altura de Izaje Standard (Customizable)	66 ft / 20 m	Rango de temperatura de Trabajo	-20°C to 70°C
Numero de Velocidades	1 Speed	Presión Aire	4 - 7 Bar
Velocidad de Izaje a Plena Carga	0.55 m/min	Dimensión Entrada Aire	3/4 BSP
Velocidad de Izaje Sin Carga	1.4 m/min	Dimensión Tubería Aire	19mm - 25mm (3/4" - 1")
Velocidad de Bajada a Plena Carga	1.8 m/min	Consumo Aire	3.11 m3/min
Máxima Sobrecarga Segura	Overload Protection Slip Clutch 130% WLL	Tipo Transmisión / Reductor	Epicycle Gearbox (Grease Filled and Sealed)
Protección Antiexplosión	- EX 2 GD IIA T4 - EX 2 GD IIB T4 - EXCLUDES Hydrogen Disulphide or Ethelene Oxide - ZONES 1, 2 AND 21, 22	Tipo de Cadena	G80 RUG Germany 5:1 Safety Factor
Exclusiones de Protección	- HYDROGEN DISULPHIDE - ETHELENE OXIDE	Dimensiones de la Cadena	16 x 45 mm
Distancia de Control	64 ft / 19.5 m	Caidas de Cadena	4
Clase de Servicio	100% Duty Cycle	Temperatura	-20°C to 70°C
Tipo de Motor	Vane Rotary Motor - Lubrication Free - Rust Free & Replaceable Stainless Steel Cylinder	Nivel de Ruido	84 dBA @ 1m
Potencia Motor	3.2 kw	Normas	ASME B30.11 /B30.16 /HST-5 DIN EN818-7 SANS 1638 compliant ATEX EX Classification according to EC Directive on Hazardous Locations 94/9/EEC
Freno Motor	>125% WLL Automatic self-adjusting multidisc Brake	Fabricado en	South Africa
Control	Pendant Control w/emergency stop	Garantía	3 Year

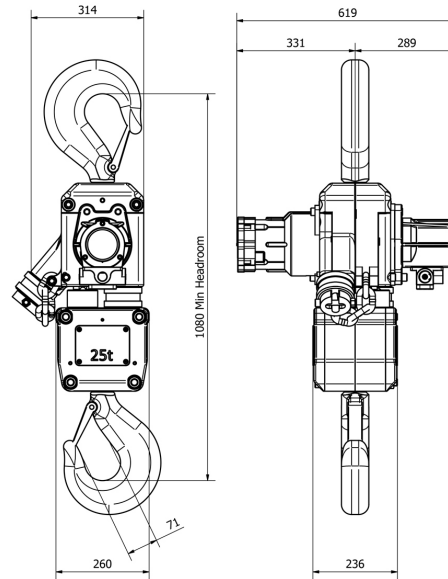
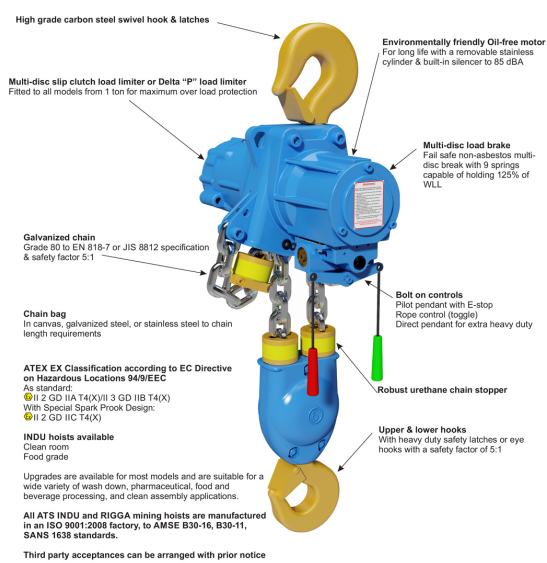

Peso & Dimensiones

H Altura Muerta	1080 mm
W Ancho	619 mm
D Depth	314 mm
J Boca Gancho	71 mm

Referential Images / Imágenes Referenciales
Specifications may change without notice / las especificaciones pueden cambiar sin previo aviso