



12 Ton Air Chain Hoist - 12 meters lifting height - RUD G80 Chain

Características Esenciales

- 3 Años de Garantía, Servicio y Atención al Cliente en Chile

Especificaciones Técnicas

Pendant Control Yes No	Included	Control	Pendant Control w/emergency stop
Pendant Control Emergency Stop	Yes	Parada de Emergencia	Yes
Capacidad de Carga	12 ton	Normas	ASME B30.11 /B30.16 /HST-5 DIN EN818-7 SANS 1638 compliant ATEX EX Classification according to EC Directive on Hazardous Locations 94/9/EEC
Altura de Izaje Estandar (Customizable)	20 ft / 6 m	Garantía	3 Year
Numero de Velocidades	1 Speed	IEC Pendant Control Protection	IP66
Clase de Servicio	100% Duty Cycle	Protección Antiexplosión	- EX 2 GD IIA T4 - EX 2 GD IIB T4 - EXCLUDES Hydrogen Disulphide or Ethelene Oxide - ZONES 1, 2 AND 21, 22
Tipo de Motor	Vane Rotary Motor - Lubrication Free - Rust Free & Replaceable Stainless Steel Cylinder	Fabricado en	South Africa
Freno Motor	>125% WLL Automatic self-adjusting multidisc Brake		

PWRN models

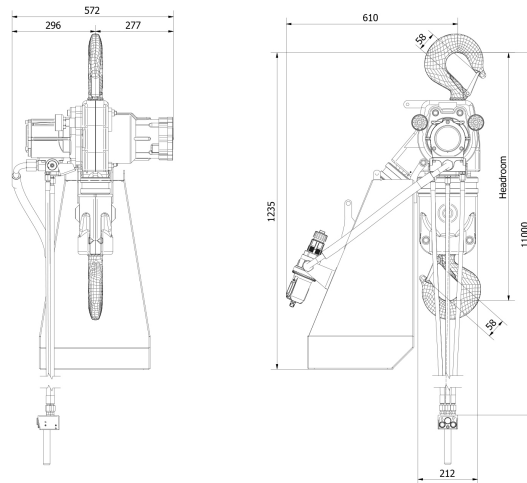

Referential Images / Imágenes Referenciales
Specifications may change without notice / las especificaciones pueden cambiar sin previo aviso