



Polipasto Cadena con Carro - Neumatico Anti explosion de 1,5 Tons ATEX

Características Esenciales

- 1.5 Tons Pneumatic Chain Hoist with trolley - Heavy Duty - Explosion Proof
- RUD G80 chain made in Germany - 9 meters lifting height (other heights available upon request) Safety factor 5:1
- Includes: Multi-disc slip clutch load limiter / Pendant Control with emergency stop (8 meters) / Chain containers
- Meets and exceeds ASME B30.16 B30.17 / HST-5 standards / Load Test at 130% SWL / ATEX Directive
- 3 Años de Garantía, Servicio y Atención al Cliente en Chile

Especificaciones Técnicas

Capacidad de Carga	1.5 Ton	Dimensión Entrada Aire	1/2" BSP
Altura de Izaje Estandar (Customizable)	20 ft / 6 m	Dimensión Tubería Aire	13 mm (1/2")
Numero de Velocidades	1 Speed	Consumo Aire	75 cfm / 2.1 m3/min
Velocidad de Izaje a Plena Carga	8.8 m/min	Tipo Transmisión / Reductor	Epicycle Gearbox (Grease Filled and Seald)
Velocidad de Izaje Sin Carga	13 m/min	Tipo de Cadena	G80 RUG Germany 5:1 Safety Factor
Velocidad de Bajada a Plena Carga	13.5 m/min	Dimensiones de la Cadena	9 x 27 mm
Máxima Sobrecarga Segura	Overload Protection Slip Clutch 130% WLL	Caidas de Cadena	1
Protección Antiexplosión	EX 2 GD IIA T4 EX 2 GD IIB T4 EX 2 GD IIC T4 ZONES 1, 2 AND 21, 22 - Copper Coated: Chain hook, bottom block, Sprocket, Load sleeve, Safety Catch - Stainless Steel Wheels	Longitud de cadena	9 m
Exclusiones de Proteccion	- HYDROGEN DISULPHIDE - ETHELENE OXIDE	Potencia del Trolley	0.3 kW
Clase de Servicio	100% Duty Cycle	Nivel de Ruido	84 dBA @ 1m
Tipo de Motor	Vane Rotary Motor - Lubrication Free - Rust Free & Replaceable Stainless Steel Cylinder	Velocidad del Trolley /min	12 m/min
Potencia Motor	1.4 kw	Cantidad de Velocidades	1
Freno Motor	>125% WLL Automatic self-adjusting multidisc Brake	Rango de ancho de la Viga	65 - 280 mm
Control	Pendant Control 4 buttons w/emergency stop	Radio Minimo de Giro	1.5 m
Parada de Emergencia	Yes, on pendant Control	Normas	ASME B30.11 / B30.16 / B30.17 / HST-5 DIN EN818-7 SANS 1638 compliant ATEX EX Classification according to EC Directive on Hazardous Locations 94/9/EEC
Rango de temperatura de Trabajo	-20°C to 70°C	Fabricado en	Southafrica
Presión Aire	4 - 6 Bar	Garantía	3 Year

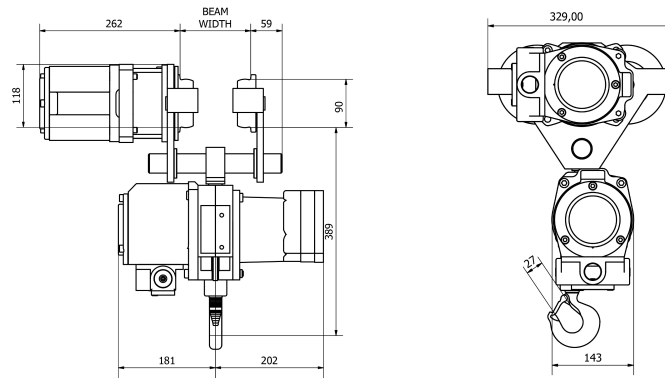

Peso & Dimensiones

H Altura Muerta

402 mm

Referential Images / Imágenes Referenciales
Specifications may change without notice / las especificaciones pueden cambiar sin previo aviso