



## 2 Speed 11,000 lbs. 5 Tons. Power Trolley 3 Phase. Pendant control not included.

### Características Esenciales

- 3 Años de Garantía, Servicio y Atención al Cliente en Chile

## Especificaciones Técnicas

Capacidad de Carga	11000 lb / 5000 kg	Rango de ancho de la Viga	100-178 mm
Voltaje	3 Phase 208~240/440~480V 50/60Hz	Radio Minimo de Giro	4.9 ft / 1.5 m
Potencia Total Watts	0.75 kW	Garantía	3 Year
Velocidad del Trolley /min	36 - 68 ft /11 - 21 m		

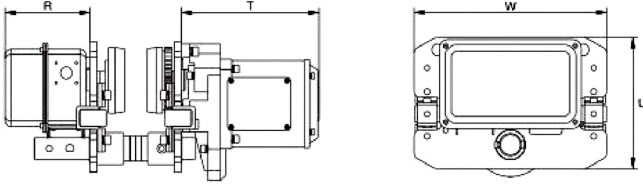

Model / Modelo	PWQE1Ti	PWQE2Ti	PWQE3Ti	PWQE5Ti	PWQE7Ti	PWQE10Ti	
Dimensions / Dimensiones	<b>W</b>	12.4 in / 315mm	12.7 / 325mm	13.3in / 340mm	15.7 in/ 400mm	26.5 in / 670 mm	19.6in / 500mm
	<b>U</b>	8.3 in / 212mm	8.6mm / 220mm	9.8 in / 250mm	11.4 in / 291mm	-	14.6in / 371mm
	<b>R</b>	5.5 in / 142mm	5.5 in / 142mm	5.5 in / 142mm	5.5 in / 142mm	9 in / 231 mm	5.5 in / 142mm
	<b>T</b>	9 in / 231mm	9 in / 231mm	9 in / 231mm	9 in / 231mm	5.6 in / 142 mm	9 in / 231mm

## Peso & Dimensiones

## Detalles del Empaque

<b>T Motor del Carro</b>	5.6 in / 142 mm	<b>Paquete 1 Peso Neto</b>	187 lbs / 85 Kg
<b>D Depth</b>	17 in / 430 mm	<b>Paquete 1 Ancho</b>	17 in / 43.18 cm
<b>R Carro Ancho Caja</b>	9 in / 231 mm	<b>Paquete 1 Peso Bruto</b>	206.8 lbs / 94 Kg
<b>W Ancho</b>	26.5 in / 670 mm	<b>Paquete 1 Altura</b>	19 in / 48.26 cm
<b>Peso Total</b>	206.8 lbs / 94 Kg	<b>Paquete 1 Profundidad</b>	27 in / 68.58 cm

Referential Images / Imágenes Referenciales  
 Specifications may change without notice / las especificaciones pueden cambiar sin previo aviso