



Carro Electrico 3 Fases 5 Toneladas. Botonera No Incluida

Características Esenciales

- 3 Años de Garantía, Servicio y Atención al Cliente en Chile

Especificaciones Técnicas

Capacidad de Carga	11000 lb / 5000 kg	Rango de ancho de la Viga	4~7 in / 100~178 mm
Voltaje	3 Phase 208~240/440~480V 50/60Hz	Radio Minimo de Giro	5 ft / 1.5 m
Potencia Total Watts	0.75 kW	Normas	ASME B30.17
Velocidad del Trolley /min	43 ft / 13 m @ 60 HZ 36 ft / 11 @ 50 HZ	Garantía	3 Year

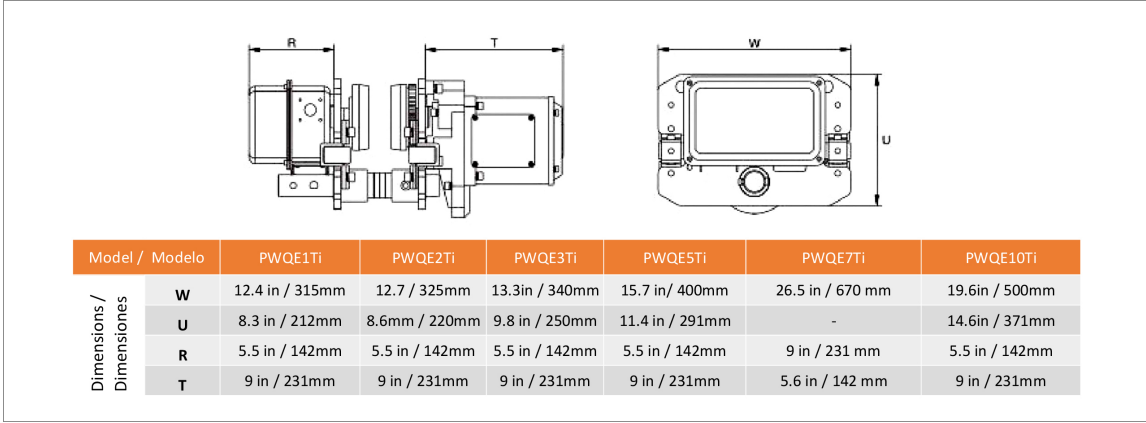

Peso & Dimensiones

Detalles del Empaque

T Motor del Carro	9.09 in / 231 mm	Paquete 1 Peso Neto	165 lbs / 75 Kg
A Altura Total	11.5 in / 291 mm	Paquete 1 Ancho	17 in / 43.18 cm
R Carro Ancho Caja	6 in / 142 mm	Paquete 1 Peso Bruto	180.4 lbs / 82 Kg
W Ancho	16 in / 400 mm	Paquete 1 Altura	19 in / 48.26 cm
Peso Total	180.4 lbs / 82 Kg	Paquete 1 Profundidad	23 in / 58.42 cm

Referential Images / Imágenes Referenciales
 Specifications may change without notice / las especificaciones pueden cambiar sin previo aviso