



3 Ton Top Running Motorized End Trucks Single Girder up to 34ft Span 220/440V 3P

Características Esenciales

- For heavy-duty class “C” single girder crane applications
- Drives and brakes are compatible with Variable Frequency Drive (VFD)
- Suitable for use on ASCE crane rail or square bar
- 3 Años de Garantía, Servicio y Atención al Cliente en Chile

For heavy-duty class “C” single girder crane applications, Top running motorized end trucks. Include 2 trucks; 2 gear motors with D.C. brakes, rubber bumpers. All trucks are fully painted. Runway Rail ASCE # 30

Especificaciones Técnicas

Capacidad de Carga	3 Ton	Freno Motor	Yes
Velocidad /min	66 ft	Protección IEC Motor	IP54
Numero de Velocidades	1 Speed - Optional Variable Speed	Variador de Frecuencia	Optional 1.1 Kw
Voltaje	3 Phase 220~240/440~480V 60Hz	Freno Dinámico	Only with VFD Optional
Potencia Total Watts	0.25 x 2	Control	Not Included. Optional single Speed, 2 Speed and Variable Speed
Luz Maxima	30 Ft	Rango de ancho de la Viga	Any
Material	Steel	Normas	ASME / CMAA / Nch
Clase de Servicio	H4/M5/2m/Class D	Garantía	3 Year

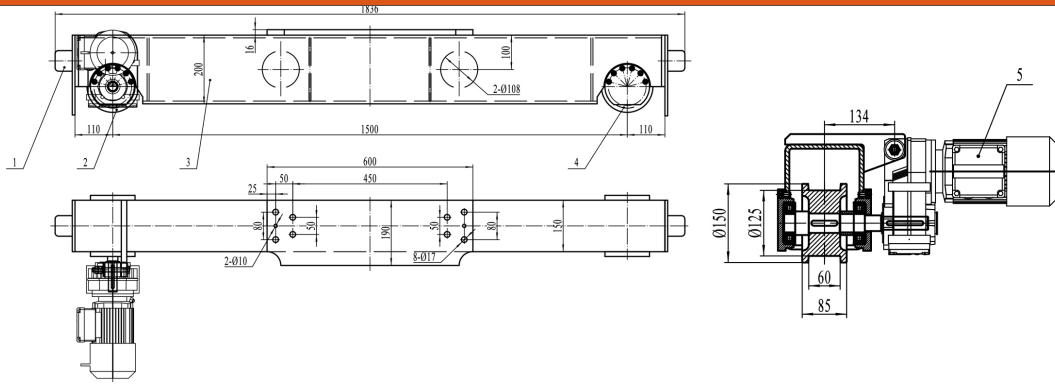

Peso & Dimensiones

Largo de testera	1500 mm
Peso Total	728 lbs / 331 Kg

Detalles del Empaque

Paquete 1 Peso Neto	980 lbs / 445 Kg
Paquete 1 Ancho	26 in / 66.04 cm
Paquete 1 Peso Bruto	728 lbs / 330 Kg
Paquete 1 Altura	30 in / 76.2 cm
Paquete 1 Profundidad	77 in / 195.58 cm

Referential Images / Imágenes Referenciales
Specifications may change without notice / las especificaciones pueden cambiar sin previo aviso