



## Winche Neumatico 2 Toneladas

### Características Esenciales

- 3 Años de Garantía, Servicio y Atención al Cliente en Chile

## Especificaciones Técnicas

<b>Capacidad 1ª Capa</b>	4400 lb / 2000 kg	<b>Cable Recomendado</b>	ø 1/2 in (x 328 ft) / ø 13 mm (x 100 m)
<b>Velocidad /min</b>	0~40 ft/min. / 0~12 m/min	<b>Humedad</b>	≤90%
<b>Numero de Velocidades</b>	Variable Speed	<b>Normas</b>	ASME B30.7/GB/T5359-2010/ANSI/EN 14492-1
<b>Control</b>	Lever Throttle / Palanca de Aceleración	<b>Garantía</b>	3 Year

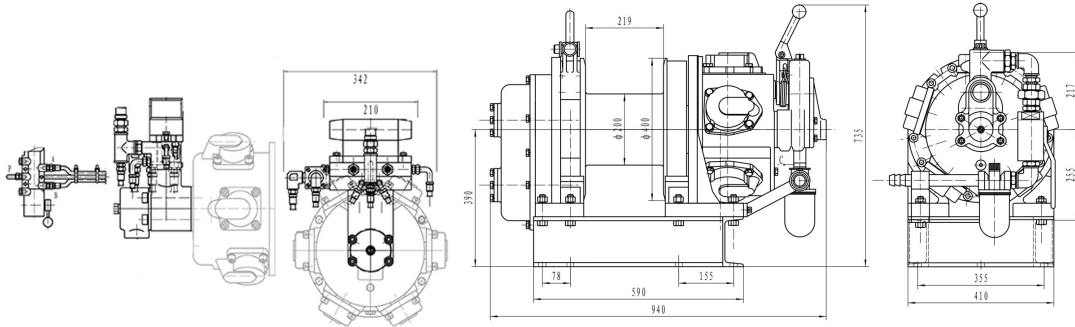

Dimensions in mm / Dimensiones en mm

Rope Diameter / Diámetro del Cable: 1/2 in   13 mm			
Nominal Strength / Resistencia Nominal: 26656 lb / 12091 kg			
Rope Weight x ft / Peso del cable x m: 1.5 lb / 0.7 kg			
INCLUDED/INCLUIDO			
Layer / Capa	Rope on drum / Mts x Capa	Lifting x layer / Cap x Capa	Speed / Velocidad (per min)
1	48 ft / 14 m	4409 lb / 2000 kg	99 ft / 230 m
2	99 ft / 30 m	4068 lb / 1845 kg	107 ft / 33 m
3	155 ft / 47 m	3776 lb / 1713 kg	115 ft / 35 m
4	214 ft / 65 m	3524 lb / 1598 kg	123 ft / 38 m
5	277 ft / 85 m	3302 lb / 1498 kg	132 ft / 40 m
6	328 ft / 100 m	3107 lb / 1409 kg	140 ft / 43 m

SERVICE FACTOR / FACTOR DE SERVICIO			
SERVICE/SERVICIO	LOAD / CARGA	TIME / TIEMPO	MAINTENANCE (Months) / MANTENIMIENTO (meses)
Normal	< 65%	< 25%	6 - 12
Heavy / Pesado	> 65%	> 25%	3 - 6
Severe / Severo	<b>Abnormal Conditions</b> En condiciones Anormales Environmental, Geographical y Risky Ambientales, Geográficas y Riesgosas < 100% < Duty Cycle limit < Limite Ciclo de Trabajo		1 - 3

## Peso & Dimensiones

## Detalles del Empaque

<b>Peso Total</b>	1102 lbs / 500 Kg	<b>Paquete 1 Peso Neto</b>	992 lbs / 450 Kg
		<b>Paquete 1 Ancho</b>	27 in / 68.58 cm
		<b>Paquete 1 Peso Bruto</b>	1102 lbs / 500 Kg
		<b>Paquete 1 Altura</b>	27 in / 68.58 cm
		<b>Paquete 1 Profundidad</b>	31 in / 78.74 cm

Referential Images / Imágenes Referenciales  
 Specifications may change without notice / las especificaciones pueden cambiar sin previo aviso