

Winche Neumatico 1 Tonelada

Características Esenciales

- 3 Años de Garantía, Servicio y Atención al Cliente en Chile

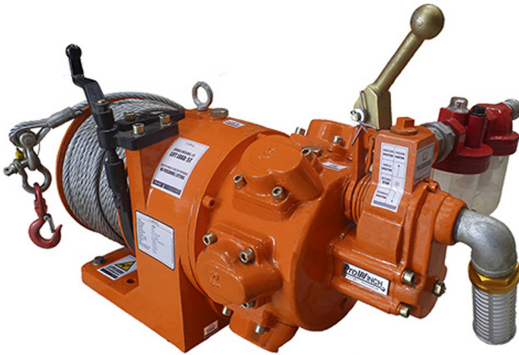

Especificaciones Técnicas

Capacidad 1ª Capa	2205 lb / 1000 kg	Cable Recomendado	ø 3/8 in (x 165 ft) / ø1 0 mm (x 50 m)
Velocidad /min	0~78 ft / 0~24 m	Humedad	≤90%
Numero de Velocidades	Variable Speed	Normas	ASME B30.7/GB/T5359-2010/ANSI/EN 14492-1
Control	Lever Throttle / Palanca de Aceleración	Garantía	3 Year

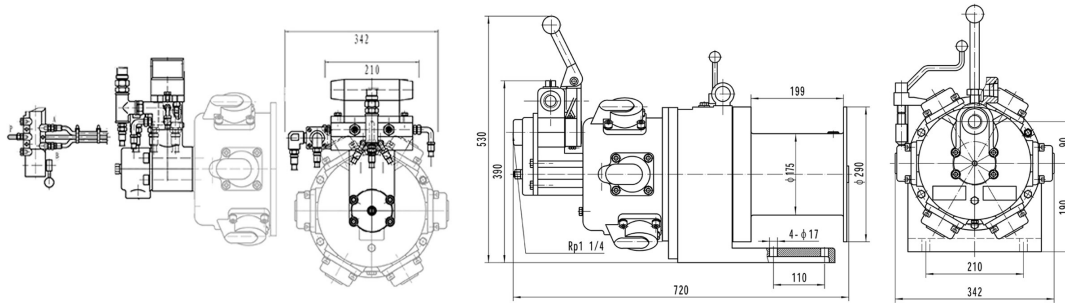

Dimensions in mm / Dimensiones en mm

SERVICE FACTOR / FACTOR DE SERVICIO			
• SERVICE/SERVICIO	• LOAD / CARGA	• TIME / TIEMPO	• MAINTENANCE (Months) / MANTENIMIENTO (meses)
Normal	< 65%	< 25%	6 ~ 12
Heavy / Pesado	> 65%	> 25%	3 ~ 6
Severe / Severo	 Abnormal Conditions En condiciones Anormales Environmental, Geographical y Risky Ambientales, Geográficas y Riesgosas	< 100% < Duty Cycle limit < Limite Ciclo de Trabajo	1 ~ 3

INCLUDED/INCLUIDO	Rope Diameter / Diámetro del Cable:	3/8 in 10 mm		
	Nominal Strength / Resistencia Nominal:	14718 lb / 6676 kg		
	Rope Weight x ft / Peso del cable x m:	0.8 lb / 0.4 kg		
	Layer / Capa	Rope on drum / Mts x Capa	Lifting x layer / Cap x Capa	Speed / Velocidad (per min)
	1	32 ft / 10 m	2205 lb / 1000 kg	68 ft / 20.7 m
	2	68 ft / 21 m	1983 lb / 899 kg	75.6 ft / 23.1 m
3	108 ft / 33 m	1801 lb / 817 kg	83.2 ft / 25.4 m	
4	151 ft / 46 m	1651 lb / 749 kg	90.8 ft / 27.7 m	
5	262 ft / 80 m	1523 lb / 691 kg	98.5 ft / 30 m	

Peso & Dimensiones

Detalles del Empaque

Peso Total	220 lbs / 100 Kg	Paquete 1 Peso Neto	220 lbs / 100 Kg
		Paquete 1 Ancho	39 in / 99.06 cm
		Paquete 1 Peso Bruto	220 lbs / 100 Kg
		Paquete 1 Altura	39 in / 99.06 cm
		Paquete 1 Profundidad	39 in / 99.06 cm

Referential Images / Imágenes Referenciales
 Specifications may change without notice / las especificaciones pueden cambiar sin previo aviso