



Tecle Polipasto Prowinch c/carro electrico 50 Tons 20 Metros trifasico

Características Esenciales

- Equipo de Doble Velocidad, Alturas de Izaje de hasta 50 m Flexible (Según requerimiento).
- Sistema de Frenado Automático, Botonera tipo Hombre Muerto con Parada de Emergencia y Encendido.
- Limitador superior e inferior. Contactores Schneider o EATON.
- Opcionales: Variador de Frecuencia con freno Dinámico, limitadores del carro y Control Remoto.
- 3 Años de Garantía, Servicio y Atención al Cliente en Chile

Electric Wire Rope Hoist Description

Single Girder 50 Ton Wireless Electric Wire Rope Hoist. Includes Overload Protection, Limit Switches for all movements, Electric Control box with VFD Control for Traveling and Lifting. Wireless Remote F24-4D and Pendant Control

Especificaciones Técnicas

Capacidad de Carga	110200 lb / 50000 kg	Freno Dinámico	Yes
Altura de Izaje Estandar (Customizable)	66 ft / 20 m	Control	Pendant Control and Wireless F21-4D
Velocidad /min	1.0 - 6.5 ft/min 0.3 - 2.0 m/min	Voltaje del Control	Optional Wireless F2124 V
Numero de Velocidades	2 Speed	Contactador	Schneider or EATON
Voltaje	3 Phase 208~240/440~480V 50/60Hz	Humedad	<85%
Voltajes Disponibles	460V-US / 380V-CHILE	Temperatura	-4°~104° F / -20°~40° C
Clase de Servicio	H3/M4/1Am/Class C	Potencia del Trolley	1.8 kW (x6)
Tipo de Motor	Squirrel Cage Induction Motor	Nivel de Ruido	84 dB
Potencia Motor	22.2 kW 3 Ph	Velocidad del Trolley /min	13 - 79 ft/min 4 - 24 m/min
RPM Motor	1728@60Hz 1440@50HZ	Cantidad de Velocidades	2
Grado de Aislacion	F	Radio Minimo de Giro	Not Available
Protección IEC Motor	IP54	Normas	ASME HST-4 , ASME B30.16 , B30.17 , EN14492-2 , EN60204-32
Protección Tablero de Control	IP65	Garantía	3 Year
Variador de Frecuencia	VFD Control for Lifting and Teaveling		

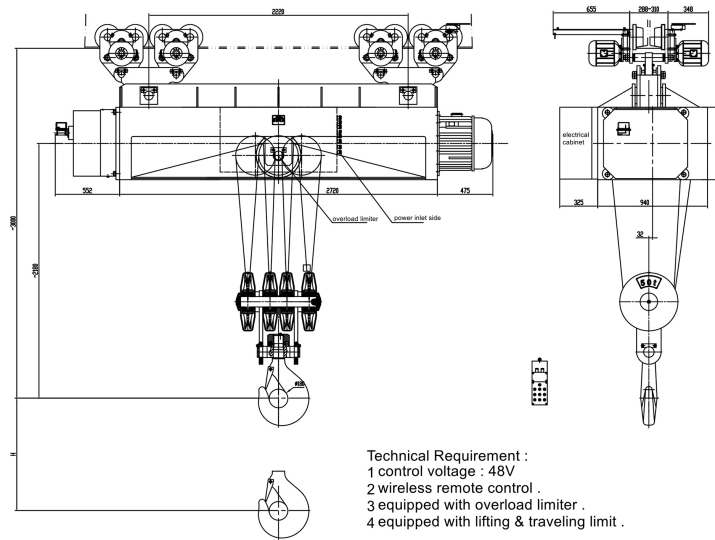

PWMD50T20M

Technical Requirement :
 1 control voltage : 48V
 2 wireless remote control .
 3 equipped with overload limiter .
 4 equipped with lifting & traveling limit .

Capacity	kg	50000
Lifting height	m	20
Lifting Speed	m/min	0.3-2.1 (Limp.)
Traveling Speed	m/min	4-24 (Limp.)
Power Supply		480V 60Hz 3Ph
Working Duty		K3
Lifting Motor	power	22.2 kW
	speed	1150 r/min
Wire Rope EN12088		G1021-433-20623
Traveling Motor	power	6x1.8 kW
	speed	1536 r/min
Weight Working Duty	mm	120
Wear	material	G8706-08 50a-63c
	mm	
Weight	kg	
General Drawing	MD Single Girder Wire Rope Hoist	
	PWMD50T20M	
Dated : May 05th , 2023	50Ton +20M	



Peso & Dimensiones

H Altura Muerta	118.12 in. / 3000 mm
J Boca Gancho	7.09 in. / 180 mm
D Depth	900 mm
X Diametro Rueda	6.7 in / 170mm (x16)
W Ancho	2500 mm

Referential Images / Imágenes Referenciales

Specifications may change without notice / las especificaciones pueden cambiar sin previo aviso