



Cabrestante Marino Electrico de 1 Tonelada 39 ft/min

Características Esenciales

- 1 Años de Garantía, Servicio y Atención al Cliente en Chile

Copyright: The pictures contained in this site belong to Prowinch LLC and are protected by copyright under national and international law. This information may not be reproduced, adapted or modified without the written consent of Prowinch LLC. The use of these images and texts implies that you should mention Prowinch LLC as owner. By consulting this site or downloading any information you agree to these conditions.

Especificaciones Técnicas

Capacidad de Carga	2200 lb / 1000 kg	Tipo de Motor	JZ2-H23-4/12
Velocidad /min	15.9 - 52.4 ft/min [4.85 - 16 m/min]	Tipo Transmisión / Reductor	Straight transmiion BLY-33-71 (Vertical Motor)
Numero de Velocidades	2 Speed	Relación de Transmisión	71 : 1
Voltaje	3 Phase 440~480V 60Hz	Cable Recomendado	48 mm
Potencia Total Watts	4.3 / 1.7 kW	Garantía	1 Year

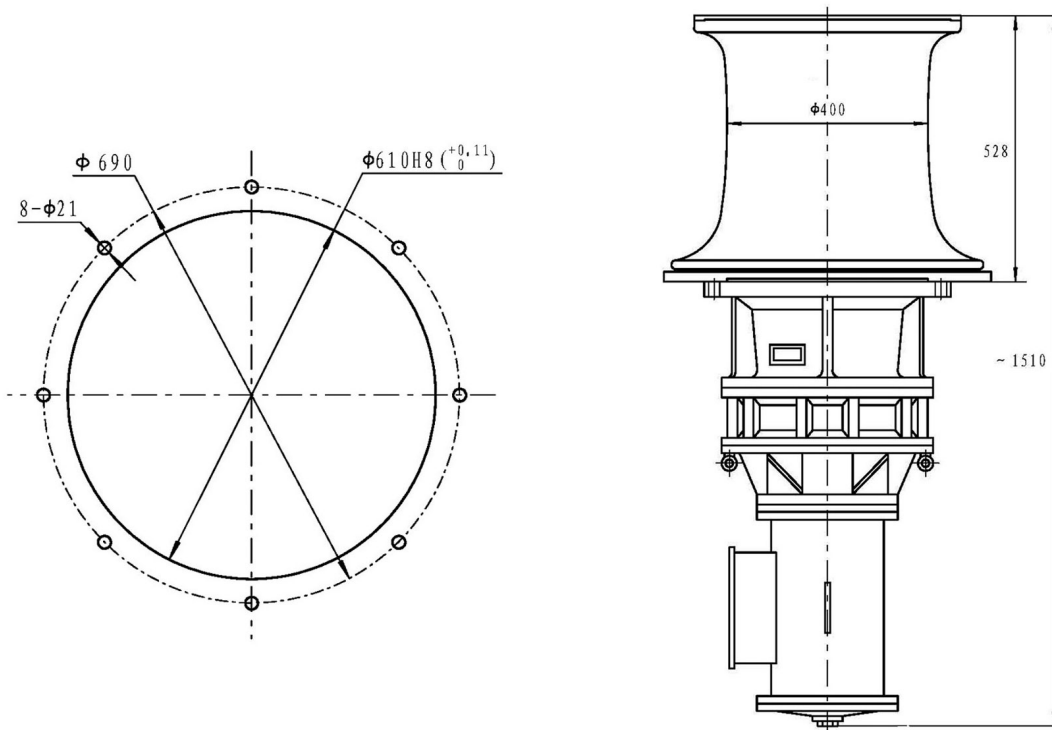

Peso & Dimensiones

BD ϕ Diámetro Tambor

260 mm

Referential Images / Imágenes Referenciales
Specifications may change without notice / las especificaciones pueden cambiar sin previo aviso