



Dinamometro 30 Tons. Aleacion liviana IP67

Características Esenciales

- 3 Años de Garantía, Servicio y Atención al Cliente en Chile

Especificaciones Técnicas

Capacidad de Carga	66000 lb / 30 ton	Peso Mínimo	440 lb / 200 kg
Grado de Precision	Grade III / n=3000	Fuente de Alimentación del Receptor	3 Battery (pilas) AA 1.5V
Intervalos de Medición	1/2/5/10/20/50 lb/kg	Rango de temperatura de Trabajo	4° - 122 °F / -20° - 50° C
Frecuencia de Muestro (por seg)	80 times/veces	Garantía	3 Year

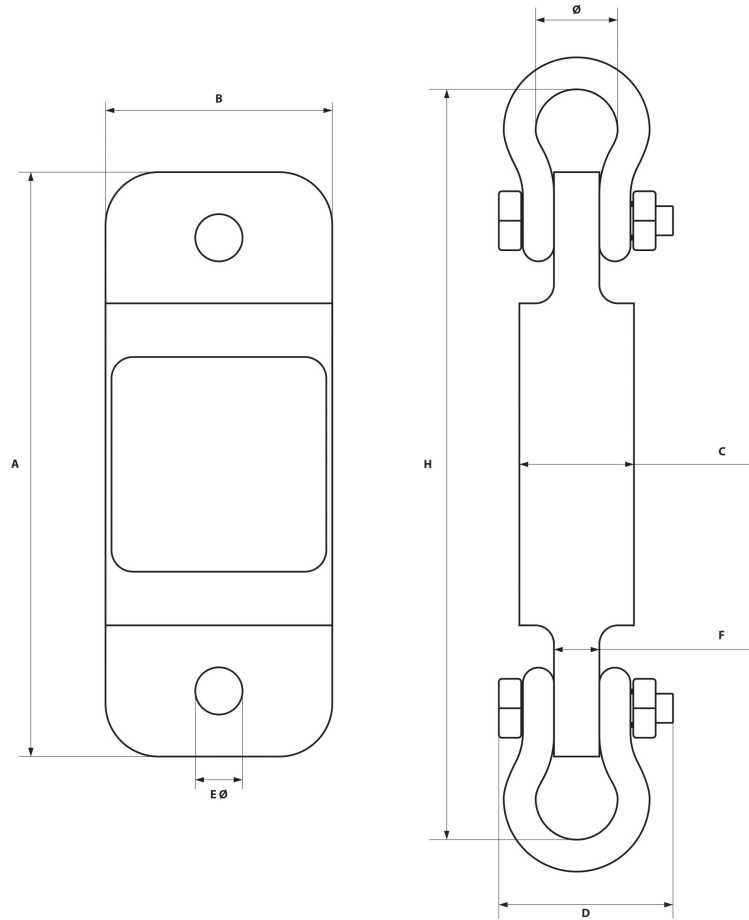

Model / Modelo	PWHYCS1T	PWHYCS5T	PWHTCS10T	PWHYCS20T	PWHYCS30T	PWHYCS50T
A	9 5/8 in	11 1/4 in	12 1/3 in	16.5 in	16.5 in	18.3 in
	244.5 mm	286 mm	318 mm	420 mm	420 mm	465 mm
B	3 3/4 in	4 in	4 1/2 in	4.8 in	5.4 in	5.9 in
	95.3 mm	102 mm	114 mm	128 mm	138 mm	150 mm
C	1 7/8 in	2 in	1 7/8 in	2.8 in	3.1 in	3.9 in
	47.6 mm	51 mm	48 mm	70 mm	80 mm	100 mm
D	2 13/16 in	4 7/8 in	6 1/2 in	10.2 in	11 in	12 in
	71.4 mm	124 mm	165 mm	260 mm	280 mm	305 mm
Ø	1 3/8 in	2 1/4 in	3 1/4 in	5 in	5.7 in	7.2 in
	34.9 mm	57 mm	83 mm	127 mm	146 mm	184 mm
H	12 in	16 in	19 1/2 in	25.9 in	29.1 in	36.6 in
	304.8 mm	406 mm	495 mm	660 mm	740 mm	930 mm
EØ	13/16 in	1 7/16 in	1 7/6 in			
	19.6 mm	37 mm	37 mm			
F	3/4 in	1 3/8 in	1 7/8 in			
	19.04 mm	35 mm	48 mm			

Peso & Dimensiones

Peso Total 48 lbs / 22 Kg

Detalles del Empaque

Paquete 1 Peso Neto 39 lbs / 18 Kg

Paquete 1 Ancho 28 in / 71.12 cm

Paquete 1 Peso Bruto 48 lbs / 22 Kg

Paquete 1 Altura 13 in / 33.02 cm

Paquete 1 Profundidad 9 in / 22.86 cm

Referential Images / Imágenes Referenciales
Specifications may change without notice / las especificaciones pueden cambiar sin previo aviso