



Tecle Cadena Manual 0.5 Tons Antiexplosion made in Japan

Características Esenciales

- 3 Años de Garantía, Servicio y Atención al Cliente en Chile

Especificaciones Técnicas

Capacidad de Carga	500 kg / 1100 lbs	Caidas de Cadena	1
Prueba de Carga	150% [Rated Load / Capacidad Nominal]	Longitud de cadena	20 ft / 6 m
Altura de Izaje Estandar (Customizable)	20 ft / 6 m	Altura Cadena de Accionamiento (Customizable)	20 ft / 6 m
Protección Antiexplosión	Ex II 2 GD c II B T105 °C	Normas	ASME B30.16 / B30.17 / ATEX Directive
Tipo de Motor	Manually Operated	Fabricado en	Japan
Control	Hand Chain	Garantía	3 Year
Dimensiones de la Cadena	5 x 15 mm		

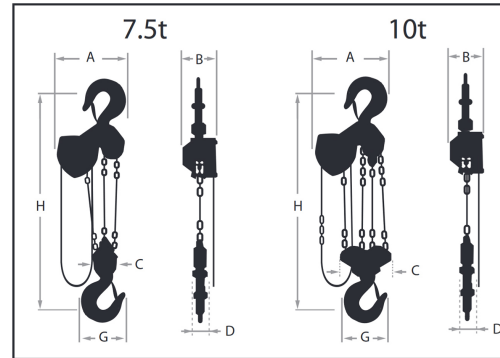
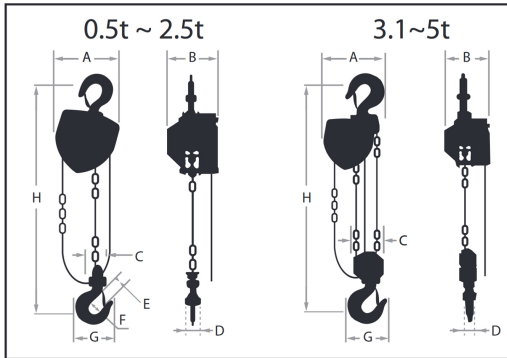

SPECIFICATIONS - PWEX H100 SPARK RESISTANT SERIES, HOOK MOUNT

Model	Max working load (lbs)	Max working load (mt)	Standard Lift (ft)	Manufacturer's Test Load	Headroom (in) "H"	Headroom (in) Lug Mount to Trolley	Hand Effort to Lift Full Working Load (lbf)	Load Chain		Hand Chain Dia. X Pitch (mm)	Net Weight (lbs)
								Dia. X Pitch (mm)	No. of Falls		
PWEX-H100-05	1100	0.5	10	150% x Max. working load	10.83	11.7	59.5	5 x 15	1	5 x 23.5	22
PWEX-H100-1	2200	1.0	10		11.81	12.5	69.5	6.3 x 19			27
PWEX-H100-2	4400	2.0	10		14.77	15.8	88.2	8 x 24			46
PWEX-H100-3	6800	3.1	10		20.87	20.5	104.7	7.1 x 21			53
PWEX-H100-5	11000	5.0	10	125% x Max. working load	24.1	24.8	105.8	9 x 27	2	5 x 23.5	87
PWEX-H100-10	22000	10.0	10		30.52	31.4	115.7	9 x 27			4

DIMENSIONS (IN.) - PWEX H100 SPARK RESISTANT SERIES, HOOK MOUNT

Capacity (lbs)	A	B	C	D	E	F	G	H
1100	5.5	6.1	2.3	1.3	1.1	1.4	2.7	10.83
2200	6.3	6.3	2.5	1.4	1.2	1.7	3.5	11.81
4400	8.5	7.2	2.6	1.6	1.5	2.1	4.5	14.77
6800	9.1	6.6	4.4	2.5	1.8	2.4	5.5	20.87
11000	11.1	7.5	6.6	3.1	2.1	2.8	6.4	24.61
22000	15.2	7.5	11.8	3.9	2.8	3.4	9	30.52



Peso & Dimensiones

Detalles del Empaque

H Altura Muerta 275 mm [10.83 in]

Tamaño Cadena de Accionamiento 5 x 23.5 mm

J Boca Gancho 28 mm [1.1 in]

Referential Images / Imágenes Referenciales
Specifications may change without notice / las especificaciones pueden cambiar sin previo aviso

