



## 1/2 Ton Electric Wire Rope Hoist 1,100 lbs. 38 ft. 110V

### Características Esenciales

- Equipo Monofásico 110V. Diseño compacto y ligero, Control Remoto IP 65 con Alcance de hasta 6 m
- Capacidad de Izaje en una línea 250kg a 10 m/min o 500kg a 5 m/min en doble línea.
- Sistema de Frenado Automático Control Remoto tipo Hombre Muerto con Parada de Emergencia y Encendido
- Incluye un freno electromagnético de acción rápida, parada de emergencia, llave de seguridad e interruptor de límite superior.
- 1 Años de Garantía, Servicio y Atención al Cliente en Chile

### Prowinch Electric Wire Rope Hoists

All of our electric wire rope hoists are created with the goal of offering the best price-performance ratio. Key components such as lifespan factors are constantly tested and improved in order to offer the best product for the price.

#### Key Components

All internal components have been upgraded to meet the highest quality standards. All testing is performed in the US before shipping to ensure that every unit meets the corresponding standard.

#### Duty Classification

Duty classification is a key factor when choosing the right unit. This H1 electric wire rope hoist is suitable for infrequent handling, installing and servicing heavy equipment, and idling for long periods between use. For uniformly distributed work periods, the hoist has a 12.5% max. operational time per hour and can handle up to 75 starts per hour. When being used for infrequent work periods, the hoist can be operated for 15 minutes from a cold start with up to 100 starts per hour. Operational time ratings are calculated at a 65% load factor, as per ASME Standards.

#### Control System

This electric wire rope hoist comes standard with an industrial wired remote control, which is waterproof, shockproof, and can be operated from 100 feet away. It also features a safety key and emergency stop button.

#### Braking System

The electromagnetic brake system is tested at 125% of the hoist capacity and is designed to automatically engage immediately upon any loss of power.

## Especificaciones Técnicas

<b>Capacidad de Carga</b>	1100 lb @ 2 lines   550 lb @ 1 line	<b>Protección IEC Motor</b>	IP40
<b>Altura de Izaje Estandar (Customizable)</b>	38ft @ 1 line / 19ft @ 2 line	<b>Control</b>	Pendant Control
<b>Velocidad /min</b>	33 ft/10m @1line   16ft/5m @2line	<b>Voltaje del Control</b>	110 V
<b>Numero de Velocidades</b>	1 Speed	<b>Parada de Emergencia</b>	YES
<b>Voltaje</b>	1 Phase 110~120V 60Hz	<b>Cable</b>	ø11/64 in   ø4.3 mm
<b>Clase de Servicio</b>	H1/M2/1Cm/Class A	<b>Humedad</b>	<85%
<b>Tipo de Motor</b>	Squirrel Cage Induction Motor	<b>Temperatura</b>	-4°~104° F / -20°~40° C
<b>Potencia Motor</b>	1450W	<b>Nivel de Ruido</b>	71 dB
<b>AMP Motor</b>	8.5 AMP	<b>Normas</b>	Intertek 4006091 , CAN/CSA C22.2 , EN14492-2 , EN60204-32
<b>Freno Motor</b>	YES	<b>Garantía</b>	1 Year
<b>Grado de Aislacion</b>	B		

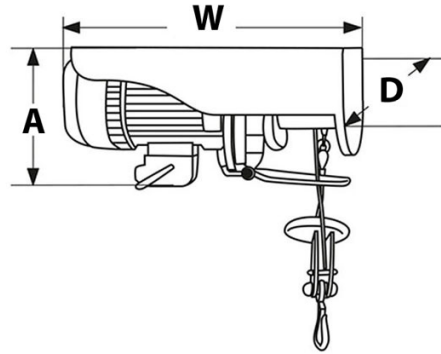

## Peso & Dimensiones

## Detalles del Empaque

<b>H Altura Muerta</b>	10.8 in / 275 mm	<b>Paquete 1 Peso Neto</b>	37 lbs / 17 Kg
<b>W Ancho</b>	13.0 in / 330 mm	<b>Paquete 1 Ancho</b>	8 in / 20.32 cm
<b>D Depth</b>	5.1 in / 130 mm	<b>Paquete 1 Peso Bruto</b>	39 lbs / 18 Kg
<b>Peso Total</b>	39 lbs / 18 Kg	<b>Paquete 1 Altura</b>	11 in / 27.94 cm
		<b>Paquete 1 Profundidad</b>	17 in / 43.18 cm

Referential Images / Imágenes Referenciales  
 Specifications may change without notice / las especificaciones pueden cambiar sin previo aviso